

- The access door is held in the 30° open position by the chain AB . If the tension in the chain is 100 N, determine (i) the projection of the tension force onto the diagonal axis CD (ii) the magnitude M of its moment about the hinge axis through point C . (20%)
- Determine the tensions in the three cables which support the uniform 90-kg plate. (15%)
- The semi-cylindrical shell of mass m and radius r is rolled through an angle of θ at which the shell slips on the horizontal surface as P is gradually increased. What value of μ_s for which the rollers will not slip. (15%)

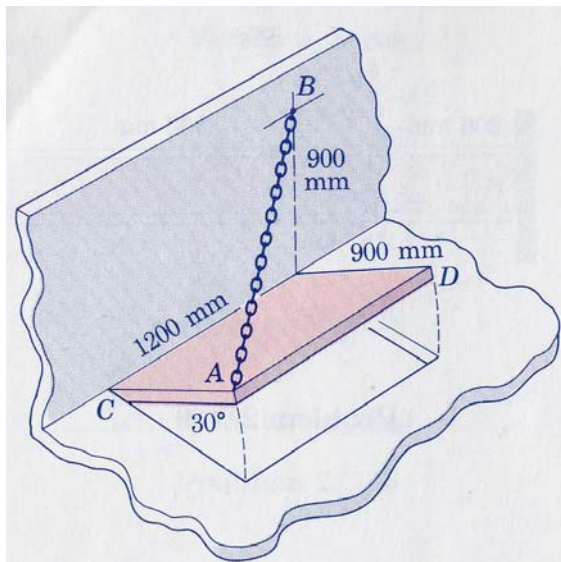

(Problem 1)

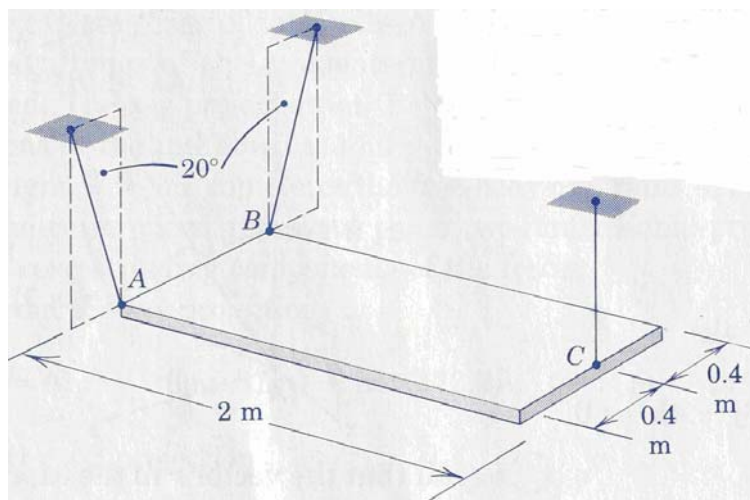

(Problem 2)

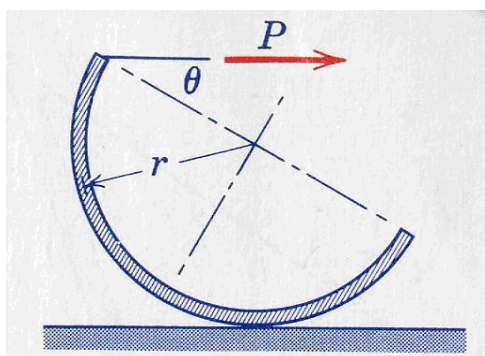

(Problem 3)

4. Starting from rest, the motorboat travels around the circular path, $\rho = 50$ m, at a speed $v = (0.2t^2)$ m/s, where t , is in seconds. Determine the magnitudes of the boat's velocity and acceleration at the moment $t = 3$ s. (15%)

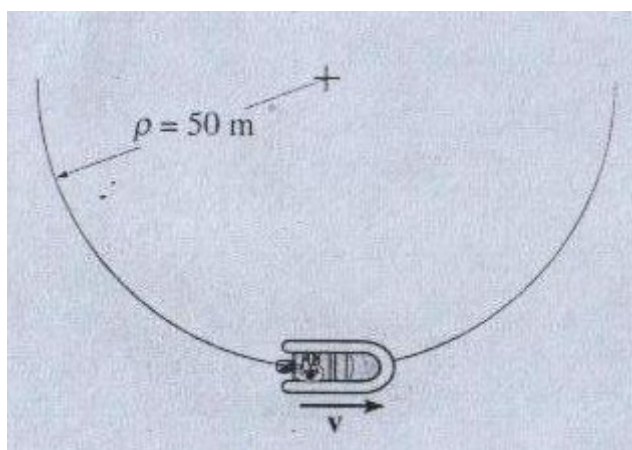

Problem 4

5. The sports car, having a mass of 1700 kg, is traveling horizontally along a 20° banked track which is circular and has a radius of curvature of $\rho = 100$ m. If the coefficient of static friction between the tires and the road is $\mu_s = 0.2$, determine the maximum constant speed at which the car can travel without sliding up the slope and the minimum speed at which the car can travel around the track without sliding down the slope. Neglect the size of the car. (20%)

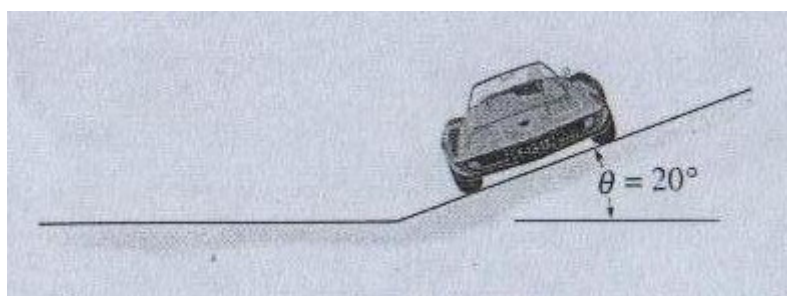

Problem 5

6. If the 1-kg smooth collar is given a velocity of 1.8 m/s to the right when $s = 0.9$ m, determine the maximum distance, $s = s_{\max}$, the collar travels before momentarily stopping. The spring has an unstretched length of 0.6 m. (15%)

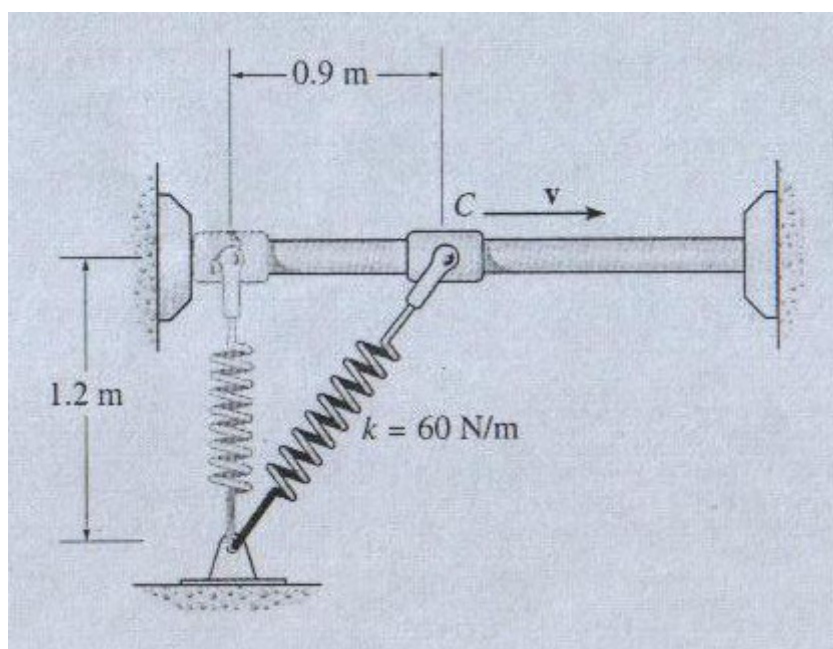

Problem 6